



SATRON®

PREON™ VDtL Differential Pressure Transmitter

www.satron.com

#LookCloser

SATRON VDtL differential pressure transmitter belongs to V transmitter family. The series V transmitters have both analog and smart properties SATRON VDtL is used for 1.4 kPa...3 MPa ranges. It is a 2-wire transmitter with HART® standard communication. In pressure measuring applications SATRON VDtL transmitters are used for liquid level, pipeline pressure and density measurements. SATRON VDtL transmitter is equipped with an SOS (Silicon On Sapphire) sensing element. Repeatability is 25:1

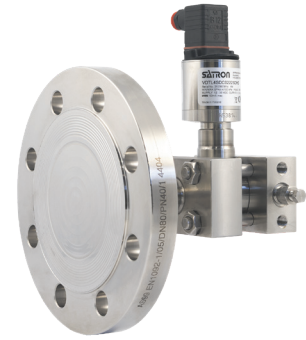

TECHNICAL SPECIFICATIONS

Measuring range and span

See Selection Chart.

Zero and Span adjustment

Zero elevation: Calibrated span is freely selectable on the specified range depending from the desired option. This can be made by using the local display option, Si-Tool or HART® communicator.

Damping

Time constant is continuously adjustable 0,01 to 60 s.

Temperature limits

Process temperature:
range 3: +10 to +80 °C
ranges 4, 5 and 6: -30 to +120 °C
Ambient temperature: -30 to +80 °C
Shipping and storage: -30 to +80 °C.
Operating temperature of display:
0 to +50°C (does not affect operation of the transmitter)

Pressure limits

Withstands 40 bar static pressure and unequal pressure load without damage to the transmitter. Pressure class: see Process Connections. See the following table for minimum pressure limits.

Minimum process pressure:

T _{proc} °C	Min. pressure for different fill fluids (kPa, abs.)	
	DC200 10 cSt	Inert oil
20	5.0	8.0
60	12.0	18.5
80	16.0	28.0
120	21.0	53.0

Volume of negative-side process chamber: 2.5 cm³

Process chamber's volumetric displacement for maximum span:
< 0.1 cm³

Output 2-wire (2W), 4-20 mA, user selectable for linear, square root, inverted signal or the transfer function (16 points) specified by the user

Supply voltage and permissible load
See the load capacity diagram;
4-20 mA output: 12 - 35 VDC .

Humidity limits

0-100 % RH; freezing of condensed water not allowed in reference pressure channels.

PERFORMANCE SPECIFICATIONS

Tested in accordance with **IEC 60770**:
Reference conditions, specified span, no range elevation, horizontal mounting;
AISI316L diaphragm, silicone oil fill.

Accuracy

±0.05 % of calibrated span
(span 1:1-5:1 /max.range).
On the measuring ranges 5:1-25:1:

$$\pm[0.01+0.012 \times \left(\frac{\text{max.span}}{\text{calibrated span}} \right)]\% \text{ of calibrated span}$$

Special accurate diaphragm **AISI304**:
±1.5 % of calibrated span.
(For spans 1:1 - 25:1)

(incl. nonlinearity, hysteresis and repeatability)

Long-term stability

±0.1 % of max. span for 12 months

Temperature effect on compensated temperature ranges

Ambient: Zero and span shift: ±0.5 % of max. span.
Process: Zero error: ±0.5 % of max.span (ranges 4,5 and 6),
±1 mbar per 10 K or min. ±0.5 % of max. span (range 3)

Static pressure effect on Zero

±0.5 % of max.span per 4 MPa

Mounting position effect

Deviati on from horizontal position causes a zero shift that can be calibrated out.

Power supply effect

< ±0.01 % of calibrated span / volt.

Insulation test voltage

500 V rms 50 Hz

CONSTRUCTION AND CALIBRATION Materials

Diaphragms 1): AISI316L (EN 1.4435), AISI304 (EN 1.4301), Duplex (EN 1.4462), Hastelloy® C276 (EN 2.4819), Nickel, Titanium Gr2 (EN 3.7035) or Tantalum.

Flanges 1) and vent valves 1): AISI316, Duplex or Hastelloy® C276.

O-ring on sensing element: PTFE.

Other sensing element materials:

AISI316, SIS 2343, SIS 2324.

Mounting bolts and nuts for sensor flanges: AISI316 (PN420: m.8.8.Zne)

Fill fluid

Silicone oil (DC200, 10 cSt) or inert fluid or food industry oil (Neobee M-20).

Housing with PLUG connector, H

Housing: AISI316

Seals: FPM

TEST jacks: MS358Sn/PVDF, protected with silicone rubber shield.

PLUG connector: PA6-GF30 jacket, Silicone rubber seal, AISI316 retaining screw.

Housing with junction box/terminal strip, M and N

Housing: AISI303/316

Seals: FPM, EPDM

Nameplates: PE

Connection cable between sensing element and housing

Codes **L** and **K** :

PTFE hose with AISI316 braiding.

Calibration

For customer-specified range with 1s damping. (If range is not specified, transmitter is calibrated for maximum range.)

Enclosure class: IP66.

Process connections

See Selection Table.

Electrical connections

Housing with PLUG connector, **H** :
PLUG connector, connector type DIN 43650 model AF; Pg9 gland for cable; wire cross-section 0.5 to 1.5 mm²

Housing with junction box/terminal strip, **M** and **N**:

Inlet M20x1.5, 1/2-NPT; screw terminals for 0.5 to 2.5 mm² wires.

PRODUCT CERTIFICATIONS

European Directive Information:
Electro Magnetic Compatibility EMC
Directive 2014/30/EU

**European Pressure Equipment
Directive (PED) 2014/68/EU**

All pressure transmitters
• Sound Engineering Practice
Transmitters with nominal pressure
higher than 200 bar fulfill the require-
ments of the Conformity Assessment
procedure Module A of the directive.

Weight (kg):

See the table; add 0,6 kg for transmitter
with screwed cap housing and 0,7 kg for
housing with display.

Type	Extension code			
	0	2	4	6
Ax, Dx, JX*,SA*	9.2	9.6 7.2	10 7.7	10.4 8.1

* process connection code

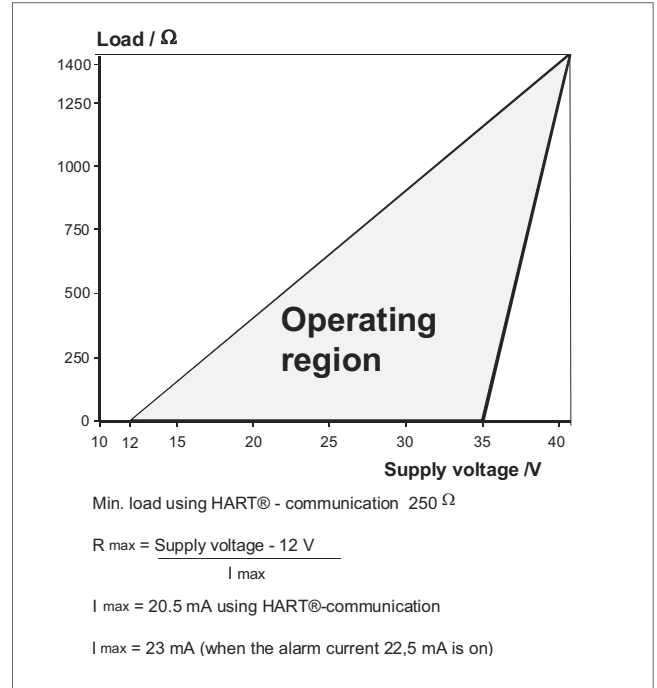

Flange size	Flange dimensions			Holes			Extension
	b	D	Ød ₄	pcs	d ₂	k	
ISO DN50 PN40	20	165	102	4	18	125	51
ISO DN80 PN40	24	200	138	8	18	160	73
ISO DN100 PN40	24	235	162	8	22	190	73
ANSI 2" 150 lbs	23	152	92	4	20	120.6	51
ANSI 2" 300 lbs	25	165	92	8	20	127	51
ANSI 3" 150 lbs	26	191	127	4	20	152.4	73
ANSI 3" 300 lbs	31	210	127	8	23	168.3	73
ANSI 4" 150 lbs	26	229	157	8	20	190.5	73
ANSI 4" 300 lbs	34	254	157	8	23	200	73
JIS 10K-50	16	155	96	4	19	120	51
JIS 40K-50	26	165	105	8	19	130	51
JIS 10K-80	18	185	126	8	19	150	73
JIS 40K-80	32	210	140	8	23	170	73
JIS 10K-100	18	210	151	8	19	175	73
JIS 40K-100	36	250	165	8	25	205	73

Process connection types Ax, Dx and Jx

Dimensions (in mm)

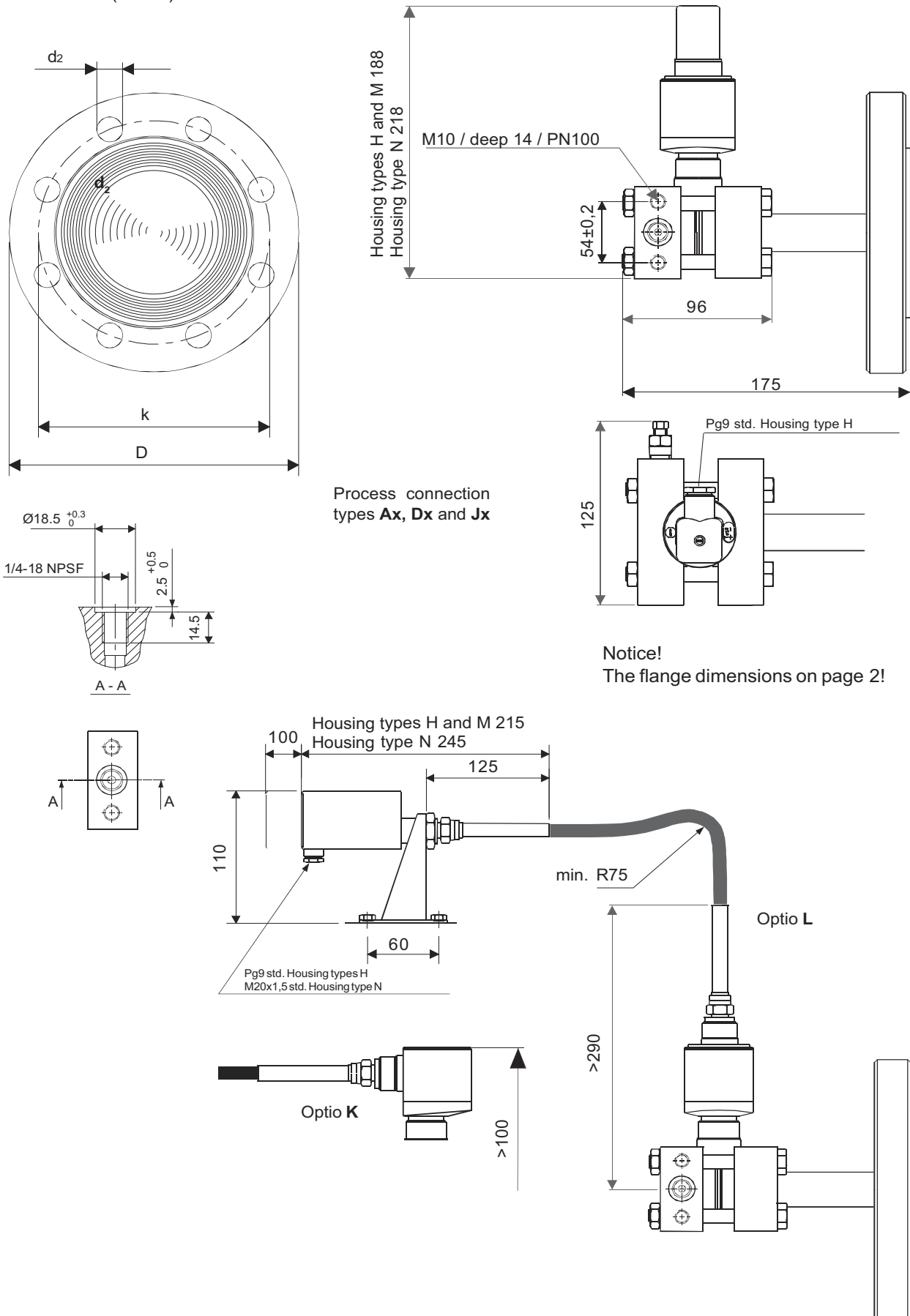

Process connection types **Ax, Dx and Jx**

Notice!
The flange dimensions on page 2!

Dimensions (mm)

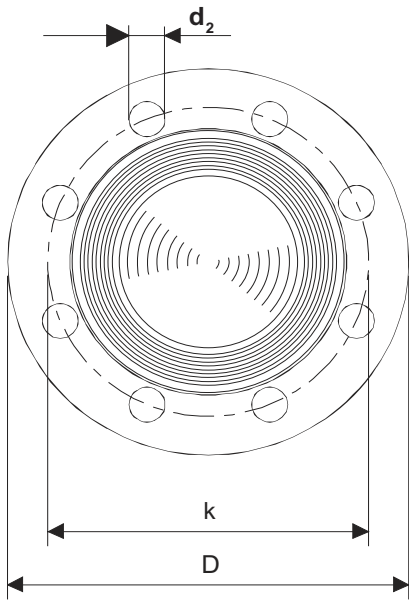

Notice!
The flange dimensions on page 2!

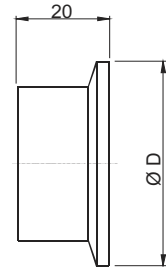
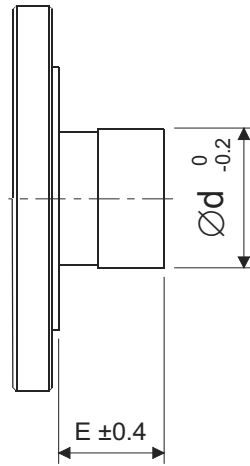

Process connection types **TA**,
TB and **TC**
- Tri-clamp DN38 ... 63,5

DN	$\varnothing D$
38	50,5
51	64
63,5	77,5

Process connection types **Ax**, **Dx** and **Jx**, with extension

	Extension code			
	0	2	4	6
Dim. E	0	51	102	152

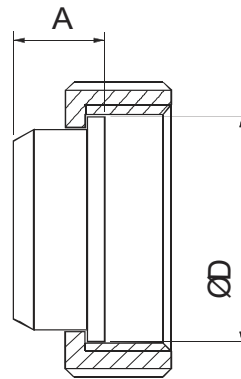
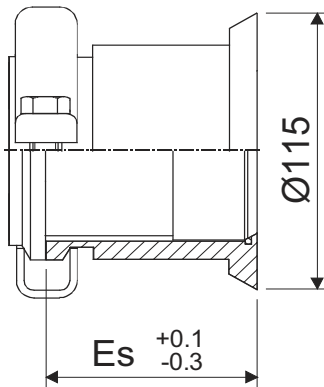

Process connection types **VA** and **VB**
- SMS38 and SMS51

Process connection type **SA**

	Extension code		
	2	4	6
Dim. Es	54.5	105	156

Size	Dimensions		Thread
	$\varnothing D$	A	
38	54	21	Rd 60 x 1/6
51	64	23	Rd 70 x 1/6

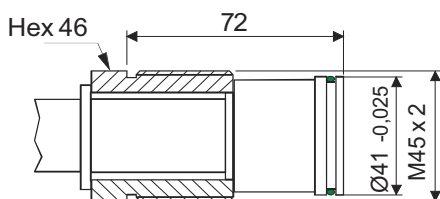

Process connection **BA**
- M45x2

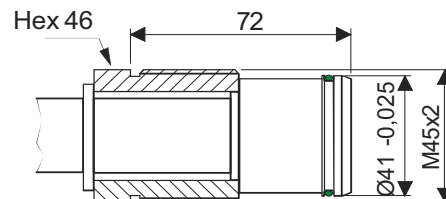

Process connection **BB**
- M45x2 with tapered

Dimensional drawings (dimensions in mm)

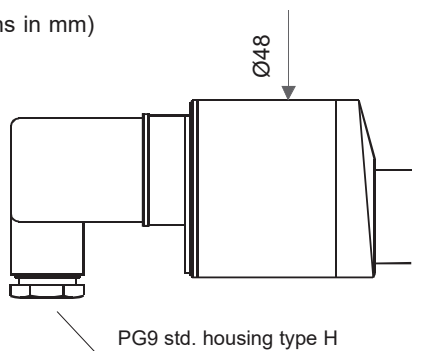

Housing with plug-connector
DIN 43650, code **H**

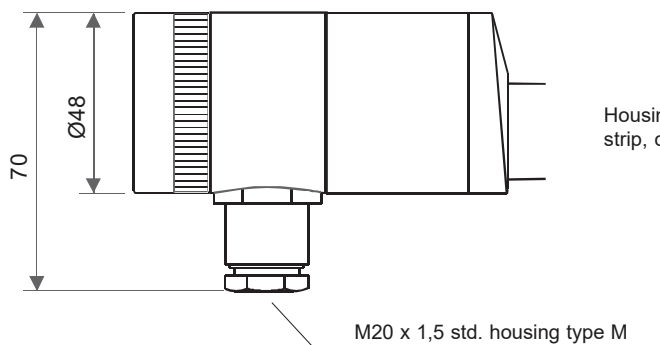

Housing with junction box/terminal
strip, code **M**

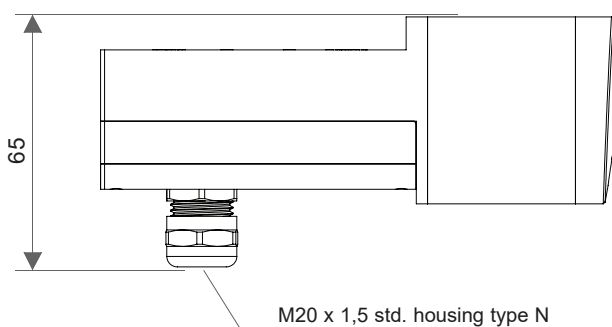

Housing with junction box/terminal
strip, with display, code **N**

